



ADMIRAL
STAGING

Original user manual

TRUSS TOPPER/ FLOOR STAND



Manufacturer:
Rolight Theatertechniek B.V.
Josink Kolkweg 10
7545 PR Enschede, The Netherlands
Phone (+31)53 432 06 44
info@rolight.nl
www.rolight.nl

Distributed by ADMIRAL

VERSION 01
December 2023
SKU: STVLADB30

www.admiralstaging.com

CONTENTS

1. INTRODUCTION
2. SAFETY INSTRUCTIONS
3. SCOPE
4. LIMITATIONS OF USE
5. TECHNICAL DATA & LOADCHART
6. IDENTIFICATION
7. EXPLANATION OF THE STICKER
8. ASSEMBLY INSTRUCTIONS
9. DISASSEMBLY INSTRUCTIONS
10. STORAGE
11. MAINTENANCE & REJECTION CRITERIA
12. WARRANTY
13. EC DECLARATION OF CONFORMITY

1. INTRODUCTION

The ADMIRAL TRUSS TOPPER / FLOOR STAND can be used to support loads when placed on the floor or as a temporary hanging bracket. They are mostly used in temporary setups in the entertainment industry but can be used for permanent setups in museums, event venues, theaters etc. as well.

In this manual ELL stands for Entertainment Load Limit. Meaning the device has an inherent double safety factor (8:1) and is therefore suitable to suspend loads above persons.

The TRUSS TOPPER / FLOOR STAND is also designed to meet the German regulation for loads above persons DGUV17/18 (formerly known as BGVc1).

Clamps, couplers and safety cables used to couple and secure the TRUSS TOPPER / FLOOR STANDS to the supporting structure are not included. The user must use certified clamps or couplers with an ELL of at least 100 kg and with minimum safety factor of 8:1 as required for overhead lifting.

ADMIRAL has endeavored to deliver the highest degree of accuracy possible. However continuous improvement of our products is ADMIRAL policy. Therefore product specifications are subject to change without notice.

Readers and users are encouraged to notify ADMIRAL of errors and send in suggestions for improvements. All communications will be carefully considered for future printings of this manual and changes to our products.

2. SAFETY INSTRUCTIONS

This user manual must be read and understood prior to assembly, setup and servicing. All people using and servicing the TRUSS TOPPER / FLOOR STAND must familiarize themselves with the safety instructions and user guidelines written in this manual. This manual needs to be accessible for all users at all times.

LEGEND



DANGER

DANGER: Indicates a hazardous situation which, if not avoided, will result in death or serious injury.
This signal word is to be limited to the most extreme situations.



WARNING

WARNING: Indicates a hazardous situation which, if not avoided, could result in death or serious injury.



CAUTION

CAUTION: Indicates a hazardous situation which, if not avoided, could result in minor or moderate injury.

NOTICE

NOTICE: Addresses practices not related to personal injury.

SAFETY INSTRUCTIONS

SAFETY INSTRUCTIONS: Is used for lists of steps, procedures or instructions that might otherwise substitute a DANGER, WARNING or CAUTION notification. Note that equivalent phrases, such as SAFE OPERATION PROCEDURES or SAFE SHUT DOWN PROCEDURE, can be used in place of the words "SAFETY INSTRUCTION".



CAUTION

DO NOT lift or load above people without the following precautions:

- A TRUSS TOPPER / FLOOR STAND must be taken out of service immediately if, during use, repair or maintenance damages are discovered.
- Remove people from the area during installation.
- Use solely instructed and/or trained personnel.
- Wear appropriate Personal Protective Equipment (PPE) such as hard hats and gloves during the installation.
- Make sure there is adequate amount of working light during the installation of the product.

3. SCOPE

The intended use of the TRUSS TOPPER / FLOOR STAND is to support loads when placed on the floor or as a temporary hanging bracket for loads of maximum 100 kg.

Loads can be lighting fixtures, video projectors, sound systems and/or equipment.

Any other way of use is considered to be a case of misuse. Solely the user is liable for any damage or injury resulting from such cases.



WARNING

Check local legislation for the application of use.

4. LIMITATIONS OF USE



WARNING

Exceeding the limitations of use can severely endanger the audience and users.



WARNING

Dynamic factor of lifting must be considered separately.

- The TRUSS TOPPER / FLOOR STAND can be operated from -20° up to 60° Celsius.
- Do not exceed the maximum ELL (entertainment load limit) stated on the product.
- Make sure the resulting forces on the supporting structure are approved by a competent person before applying the load.
- To determine the maximum suspended load on the product, all imposed loads shall be considered. e.g. the dynamic factor caused by the lifting machinery.
- Sound systems can be suspended but users must check regularly the integrity of the TRUSS TOPPER / FLOOR STAND as severe vibrations could loosen bolts/knobs.
- The TRUSS TOPPER / FLOOR STAND must be inspected by a competent person as often as required but with a minimum of 1 x per year. Records of these inspections must be kept.
- Inspect equipment before every use. A damaged TRUSS TOPPER / FLOOR STAND shall be taken out of service.
- Outdoor use shall be approved by a competent person and might influence the load capacity. Do not expose the product to full rain or snow. Outdoor use is the sole responsibility of the operator.
- In case of use in the vicinity of saltwater, the product shall be rinsed regularly with fresh water to avoid corrosion.

- It is also imperative to observe the local accident prevention regulations and/or occupational health and safety regulations.
- The support structure, on which the TRUSS TOPPER / FLOOR STAND is used, must have lightning protection when used outdoors.
- The support structure, on which the TRUSS TOPPER / FLOOR STAND is used, might need to have electric potential bonding.
- Do not use the TRUSS TOPPER / FLOOR STAND to guide currents for electric potential bonding.
- Make sure the TRUSS TOPPER / FLOOR STAND and the supporting structure are dry and free of dirt. When used as a TRUSS TOPPER / FLOOR STAND make sure the surface is dry and free of dirt.
- Use appropriate packaging to transport the products. e.g. a flightcase.
- Solely use by ADMIRAL approved parts to replace damaged or lost parts.
- Do not re-zinc steel components as they might be subject to hydrogen embrittlement.

WARNING

To be placed only in the centre of the TRUSS TOPPER / FLOOR STAND.

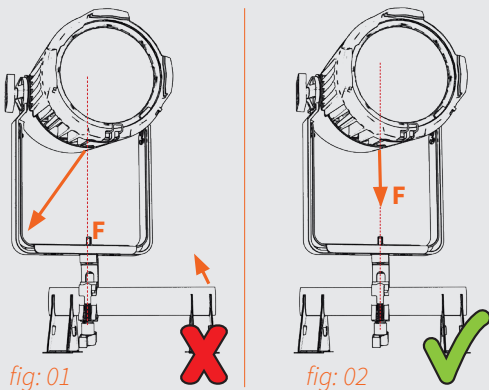

WARNING

Solely to be placed on a flat surface.

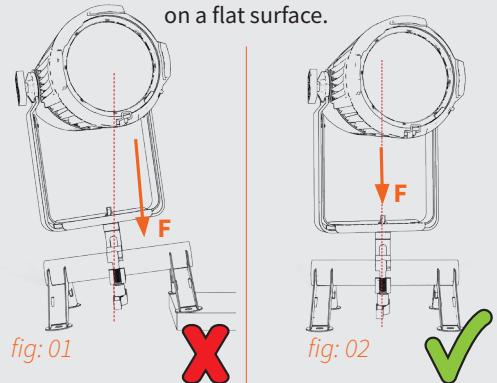

WARNING

Make sure that if the TRUSS TOPPER / FLOOR STAND is placed on a truss, it is secured with four M12 bolts 8.8 quality at all times.

WARNING

Do not suspend the TRUSS TOPPER / FLOOR STAND as shown below (fig 01). It creates torsional forces and influences the stability of the supporting structure.

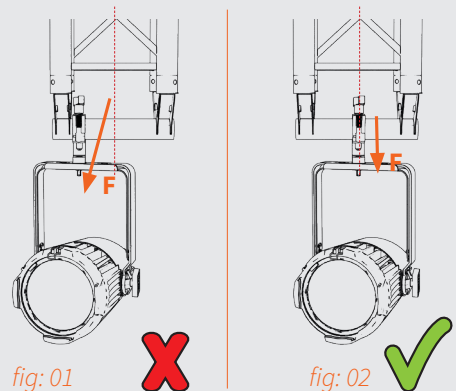

CAUTION

Do not throw the TRUSS TOPPER / FLOOR STAND, as it might damage the product.

5. TECHNICAL DATA & LOADCHART

Applicable Directives, Regulations, Standards and Information Papers

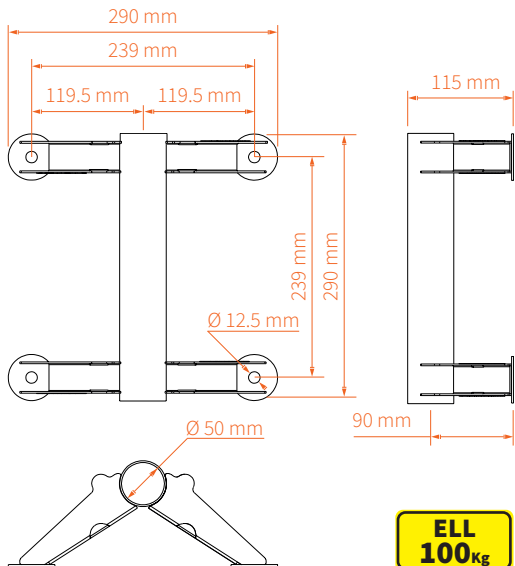

The following directive is applicable

2006/42/EC

Machinery directive

The following regulation is used

DGUV regulation 17

Regulations for stages and studios
(Formerly known as BGVC1)

Parts of the following standards and information papers are used

DGUV Information

Safety at productions and events for television, radio, film, theatre, exhibitions: Loads above persons
(Formerly known as BGI 810-3)

215-313

EN 17206:2020

Lifting and load bearing equipment for stages and other production areas within the entertainment industry

BS 7905-1:2001

Lifting equipment for performance broadcast and similar applications. Part 1 specifications for the design and manufacture of above stage equipment

Technical data

Article code:	STVLADB30
EAN:	8720094422824
ELL:	100 kg
Material:	steel
Finish:	powder coated
Colour:	black gloss 30% (RAL 9005)
Dimensions:	290 x 290 x 115 mm (L x W x D)
Weight:	1.56 kg

6. IDENTIFICATION

Front view

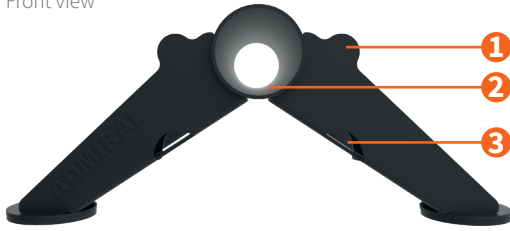

Bottom & top view



Side view



TRUSS TOPPER / FLOOR STAND

- 1 Cams to stack them properly
- 2 Pipe Ø 50 mm
- 3 Notches to stack them properly
- 4 4 legs with rubber pads

7. EXPLANATION OF THE STICKER



TRUSS TOPPER / FLOOR STAND sticker

- | | |
|----------------|----------------------------|
| 1 Brand name | 6 CE Marking |
| 2 Product name | 7 Weight |
| 3 Article code | 8 QR code to online manual |
| 4 Barcode | 9 Entertainment Load Limit |
| 5 EAN-code | |

8. ASSEMBLY INSTRUCTIONS

WARNING

Inspect the TRUSS TOPPER / FLOOR STAND before use. Make sure all components are in place and in good order. If damaged, mark the item clearly and take out of service*.

*See chapter 11 for further instructions!

Note

Only place the TRUSS TOPPER / FLOOR STAND on a level surface. Make sure it is virtually level before mounting anything on it.

Standalone TRUSS TOPPER / FLOOR STAND

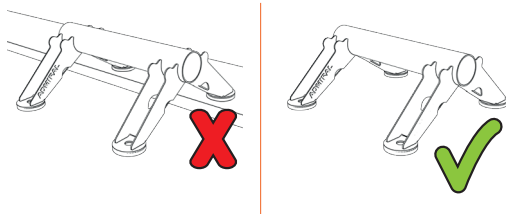

Standalone TRUSS TOPPER / FLOOR STAND

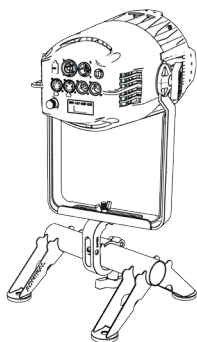

Step 1

Mount a fixture to the TRUSS TOPPER / FLOOR STAND.

TRUSS TOPPER / FLOOR STAND on a truss

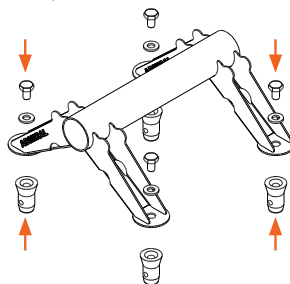

Step 1

Mount the halfcone onto the TRUSS TOPPER / FLOOR STAND with M10 or M12 bolts. Use 8.8. quality minimum. Using the maximal length possible.

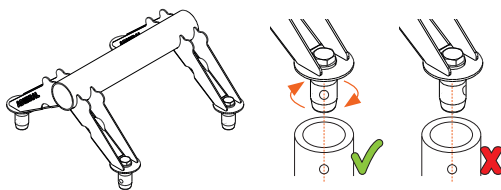

Step 2

Make sure to line out the holes in the halfcones with the holes in the truss. Tighten the bolts securely, use a torque setting of 15 Nm.

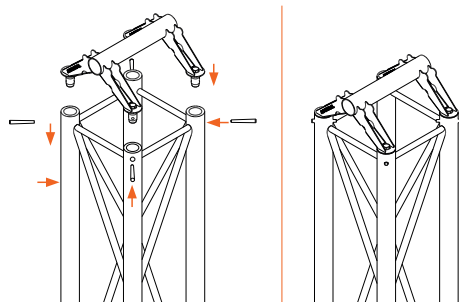

Step 3

Place the TRUSS TOPPER / FLOOR STAND on top or beneath the truss and secure the halfcone with the conical truss pin.

WARNING

Check the integrity of the TRUSS TOPPER / FLOOR STAND after severe vibrations caused by sound systems or if the supporting structure was subject to severe movement e.g. due to winds.



WARNING

If the TRUSS TOPPER / FLOOR STAND is used to support loads above people it might be needed to secure the load with an additional safety cable. Make sure this cable is attached with as less slack as possible and has the correct load capacity.

In some countries the use of safety cables is not required if the clamp and the load attached to it can only be released by use of tooling. In that case the bolt/nuts must be fastened with a minimum torque setting of 15Nm and the wingnut must be removed in order to create the condition to comply with this regulation (DGUV 215-313).

9. DISASSEMBLY INSTRUCTIONS

Step 1

Remove the conical truss pin from the halfcone.

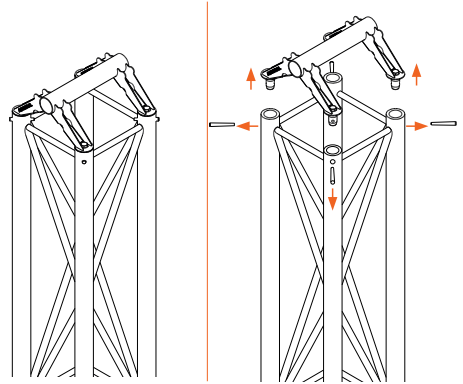

Step 2

Remove the TRUSS TOPPER / FLOOR STAND, loosen the bolts and remove the halfcones from the TRUSS TOPPER / FLOOR STAND.

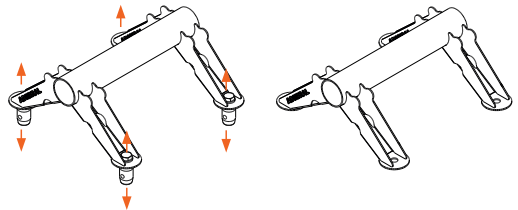

Step 3

Remove the fixture from the TRUSS TOPPER / FLOOR STAND.

10. STORAGE

The TRUSS TOPPER / FLOOR STAND must be stored in a dry, non-aggressive environment.

- Make sure the parts cannot bend.
- Avoid vibrations. Rubbing parts can cause excessive wear and tear.

11. MAINTENANCE & REJECTION CRITERIA

SAFETY INSTRUCTIONS

The TRUSS TOPPER / FLOOR STAND hardly needs any maintenance under normal use and environmental circumstances. For safety reasons however, all parts must be checked regularly for dirt, damages, loss and corrosion.

The TRUSS TOPPER / FLOOR STAND shall be checked in compliance with the local law by a competent person. Checking shall take place as often as required but with a minimum of 1x per year. In case of doubt contact ADMIRAL.



CAUTION

When replacing parts, only use genuine ADMIRAL components.

- Check all components for damages like cracks, deformations, scratches and corrosion. Damaged and corroded parts shall be rejected and thrown away.
- In general, scratches > 10% of the wall thickness mean the product needs to be rejected from use.
- In general, deformations > 10% of a straight line from the outer surface mean the product needs to be rejected from use.
- Remove all sharp and rough feeling edges and surfaces by using sand paper or a file.
- Check welds for cracks, if welds are cracked the product needs to be rejected from use.



WARNING

If damaged, mark the item clearly and take it out of service.

12. WARRANTY

- For a period of 24 months we will repair, free of charge, any damage attributable to faulty materials or workmanship under the condition that the equipment is forwarded, freight paid, to our warehouse or one of the ADMIRAL distributors' warehouses.
- The warranty-period begins with the day of the delivery, proven by a purchase receipt like an invoice or delivery note or their copies.
- The warranty does not cover damage due to transport, negligent handling, overloading the equipment or parts subject to normal wear and tear signs. Nor damages that originate from a case of misuse because of nonobservance of the safety regulations in this instruction manual.
- The warranty will be invalid when other parts than the original ADMIRAL parts have been used or modifications of our design have been made by third parties.
- Warranty repairs do not renew nor extend the warranty-period.
- In case of a claim that falls under the warranty, e.g. a malfunction or spare part requirements, please contact your point of sale or ADMIRAL.
- The manufacturer is not liable for indirect consequential damage and financial loss.
- The manufacturer shall not be liable for any changes made to the TRUSS TOPPER / FLOOR STAND parts nor for any damage resulting from such changes.

13. EC DECLARATION OF CONFORMITY



EC-DECLARATION OF CONFORMITY FOR MACHINERY (2006/42/EG Annex II)

Rolight Theatertechniek
Josink Kolkweg 10
7545 PR Enschede
The Netherlands

Herewith declares that:

ADMIRAL “TRUSS TOPPER / FLOOR STAND”; Article code **STVLADB30**

- Is in compliance with the Machinery Directive 2006/42/EC annex II
- The following harmonized standards have been applied (or parts/clauses of): EN 12100-1-2010
- The following technical regulations, standards and information papers have been used (parts/clauses of): German DGUV 17-18, German D DGUV 215-313, EN 10204:2004, EN 17206 :2020, BS 7905-1 :2001

Enschede, The Netherlands 24-November-2023

Ms. E. Dijk
Owner Rolight Theatertechniek b.v.



Rolight

