

FLEX FRAME



Manufacturer:
Rolight Theatertechniek B.V.
 Josink Kolkweg 10
 7545 PR Enschede, The Netherlands
 Phone (+31)53 432 06 44
 info@rolight.nl
 www.rolight.nl

Distributed by ADMIRAL

VERSION 02
 June 2024
 SKU: POURF110

www.admiralstaging.com

TECHNICAL DATA

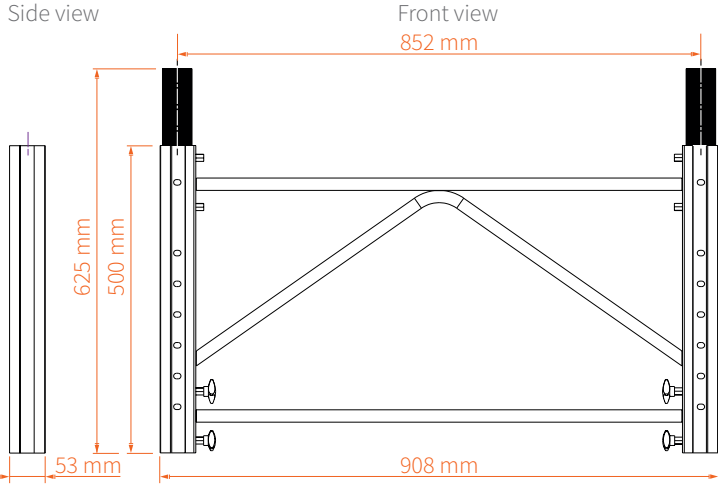

Technical data

Article code:	POURF110
EAN:	8720094420219
Max load*:	500 kg/m ²
Material:	steel
Finish:	galvanized
Dimensions:	908 x 53 x 625 mm (L x W x H)
Weight:	5.6 kg
Colour:	silver

* Max load is calculated in combination with a stage of 6 x 4 m minimum and not as a stand alone structure.

USE

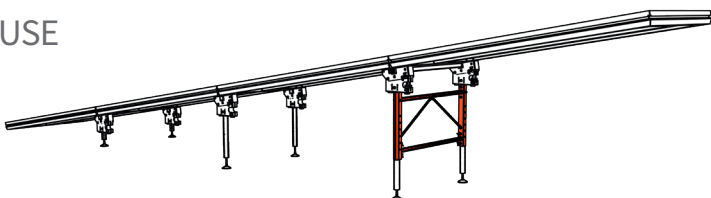

INTRODUCTION

This manual contains additional instructions to the original user manual "FLEX RAMP". It offers instruction and guidance on assembling and maintaining the FLEX FRAME.

SCOPE

The intended use of the FLEX FRAME is to ensure that a ramp built with the FLEX RAMP system remains stable when the height of the ramp support (Flex Frame and Flex Leg) is higher than 70 cm. Any other way of use is considered to be a case of misuse. Solely the user is liable for any damage or injury resulting from such cases.

SAFETY INSTRUCTIONS

WARNING

Always put the stage ramp on a level ground.

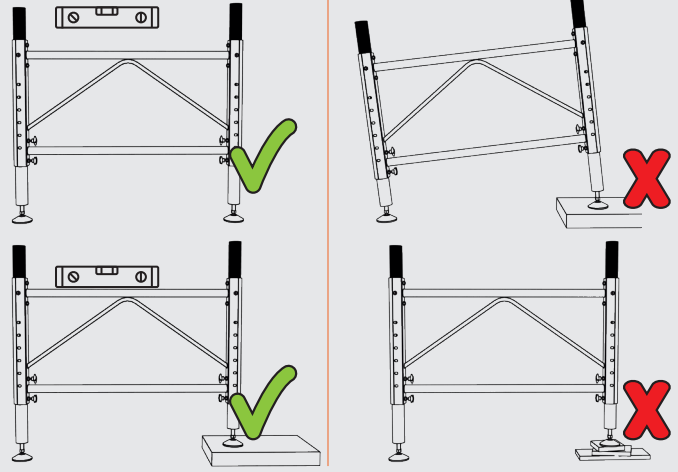

ASSEMBLY INSTRUCTIONS

Step 1

Slide the black tube (A) into both sides into the FLEX FRAME (B).

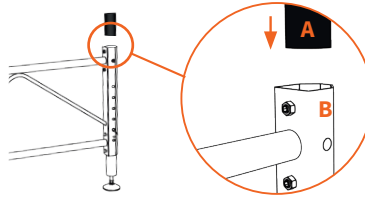

Step 2

Insert the bolt (C) through the black tube and fix the bolt and nut with a torque setting of 25 Nm.

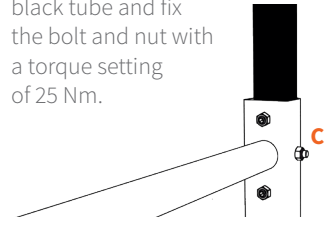

Step 3

Adjust the centre-to-centre distance of the black tubes to 852 mm. Use both hexagon sockethead screws to position the black tube (D). When measurement is reached fixate tube with a force of 25 Nm.

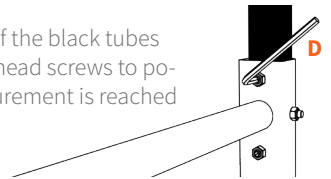

MAINTENANCE

SAFETY INSTRUCTIONS

The FLEX FRAME hardly needs any maintenance under normal use and environmental circumstances. For safety reasons however, all parts must be checked regularly for dirt, damages, loss and corrosion.

- Check all components for damages like cracks, deformations, scratches and corrosion. Damaged and corroded parts shall be rejected and thrown away.
- In general, scratches > 10% of the wall thickness mean the product needs to be rejected from use.
- In general, deformations > 10% of a straight line from the outer surface mean the product needs to be rejected from use.